

**PRIPREMNA NASTAVA**  
ARHITEKTONSKI FAKULTET

**2022**



# OBLAST PERCEPCIJE PROSTORA

## 1. PROSTORNI SKLOPOVI

### 1.1. SASTAVLJANJE PROSTORNIH SKLOPOVA

### 1.2. USPOREDNA ROTACIJA PROSTORNIH SKLOPOVA

### 1.3. ROTACIJA PROSTORNIH SKLOPOVA – VIZURE

## 2. TRANSFORMACIJA

### 2.1. TRANSLACIJA

### 2.2. ROTACIJA

## 3. ZAPAŽANJE ELEMENATA VANJSKOG I UNUTRAŠNJEG ARHITEKTONSKOG PROSTORA

## 4. CRTANJE PO SJEĆANJU



# 1. PROSTORNI SKLOPOVI

## 1.1. SASTAVLJANJE PROSTORNIH SKLOPOVA

Zaokružiti koja dva prostorna sklopa formiraju kocku (skica 1)

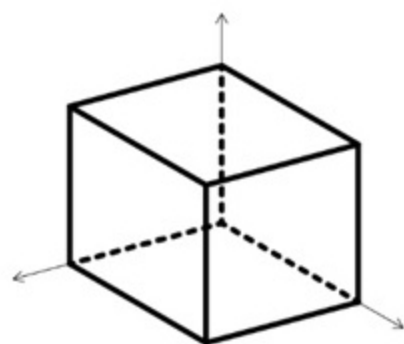

1

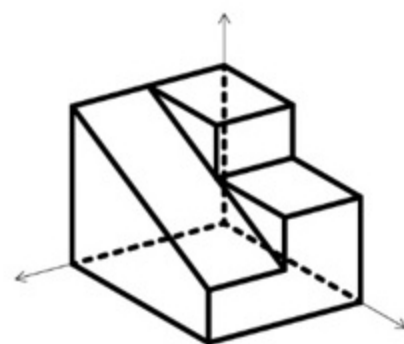

a

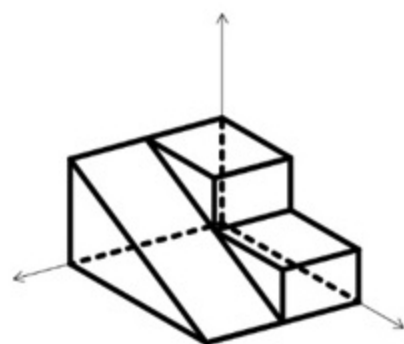

b

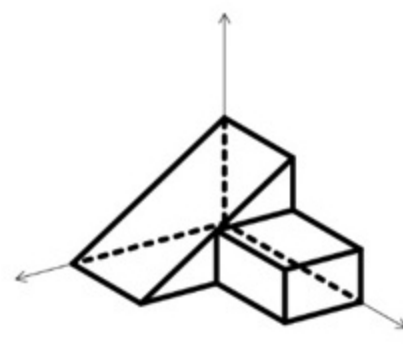

c

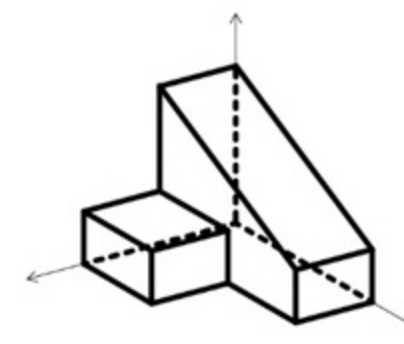

d

Niti jedan od navedenih.  
e

Zaokružiti koja dva prostorna sklopa formiraju kocku (skica 1)

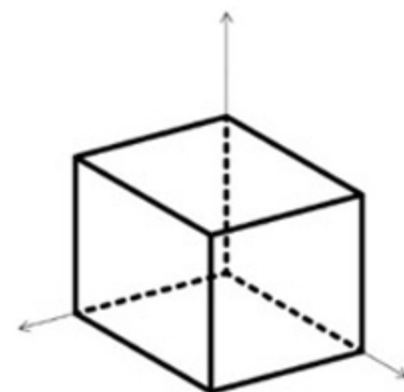

1

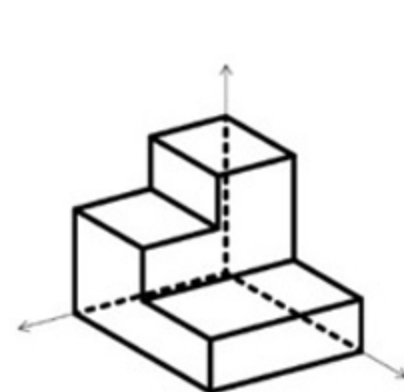

a

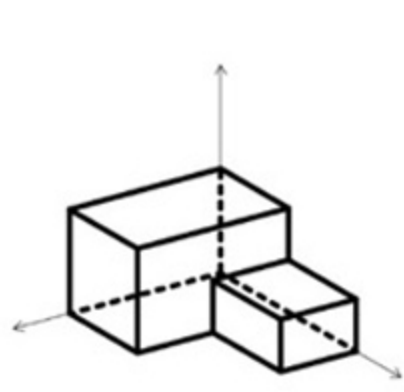

b

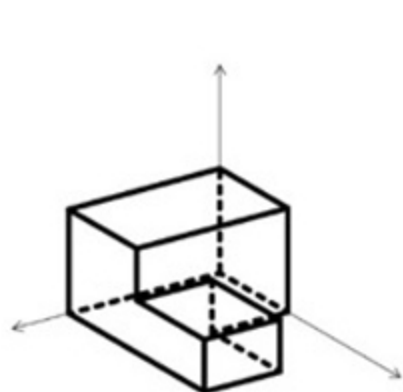

c

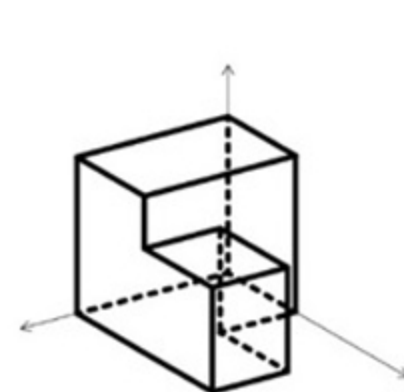

d

Niti jedan od navedenih.  
e

# 1. PROSTORNI SKLOPOVI

## 1.2. USPOREDNA ROTACIJA PROSTORNIH SKLOPOVA

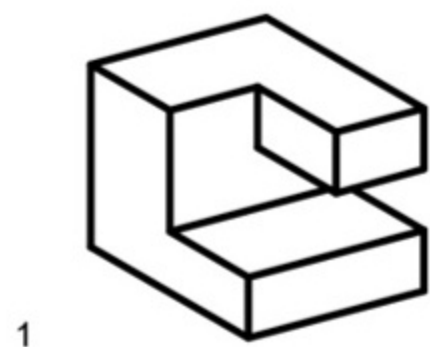

'1' je rotiran u poziciju '2'

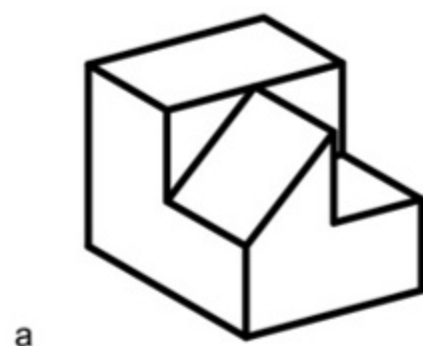
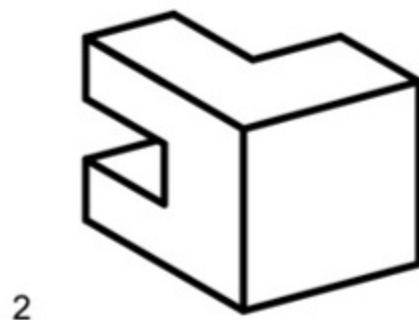

kao što je 'a' rotiran u poziciju \_\_\_\_\_

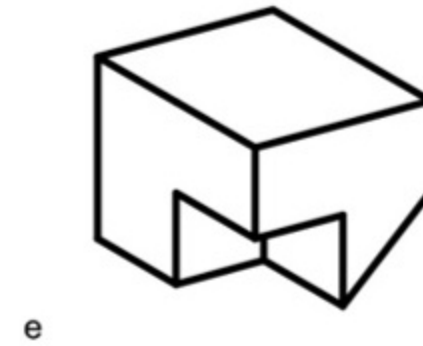
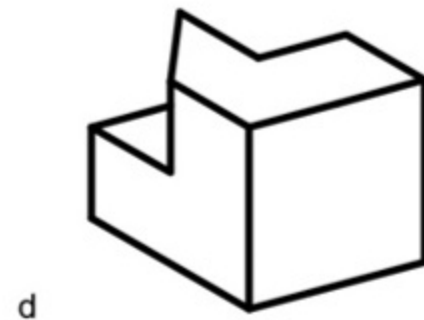
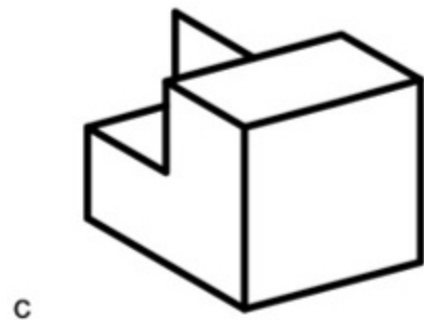
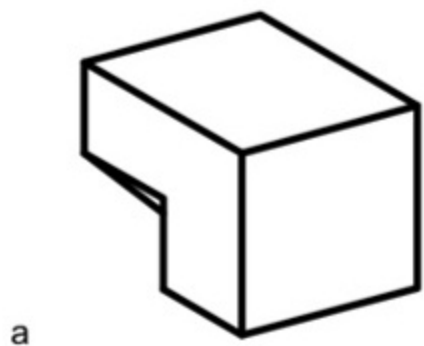



# 1. PROSTORNI SKLOPOVI

## 1.3. ROTACIJA PROSTORNIH SKLOPOVA – VIZURE

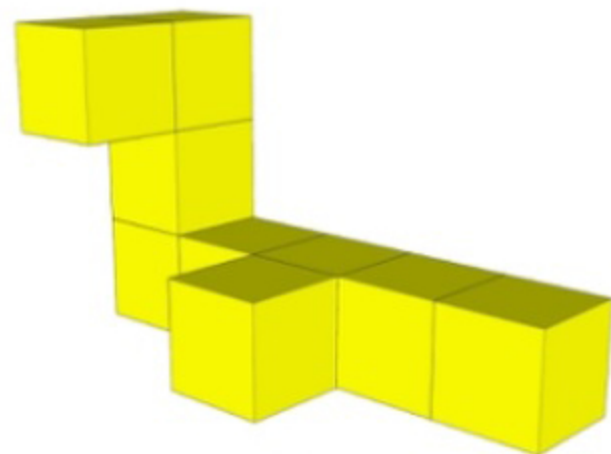
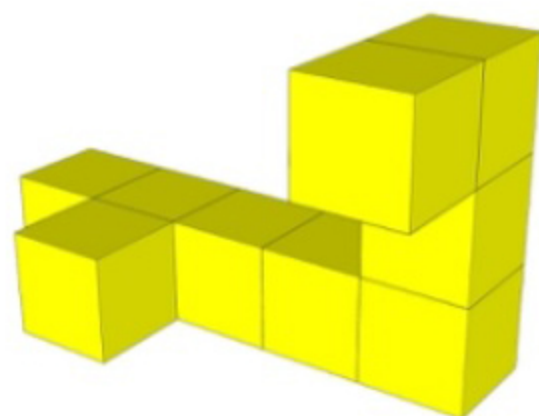

1

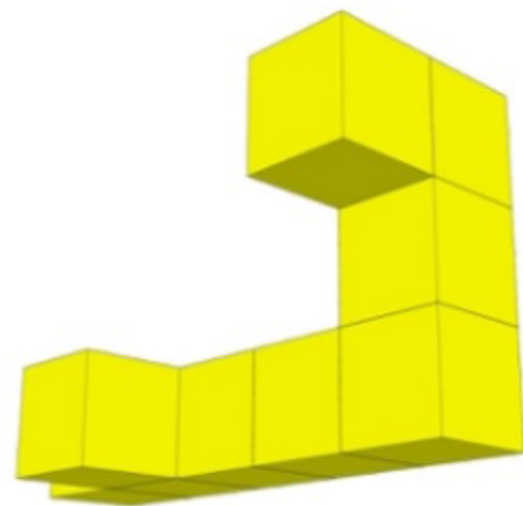

2

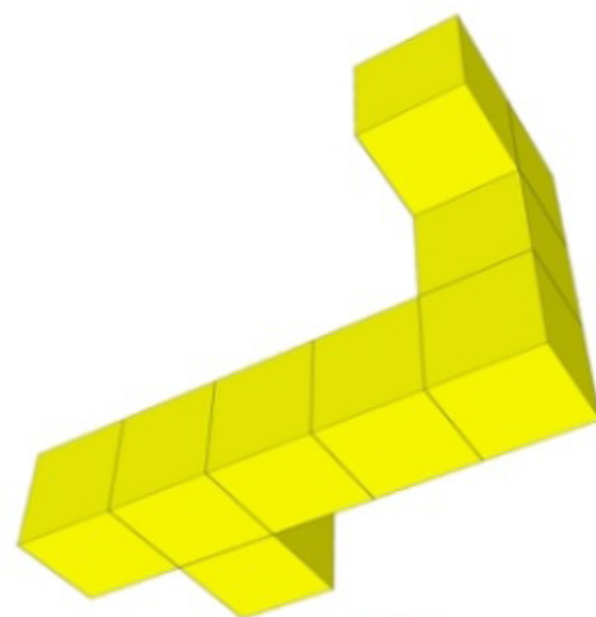

3

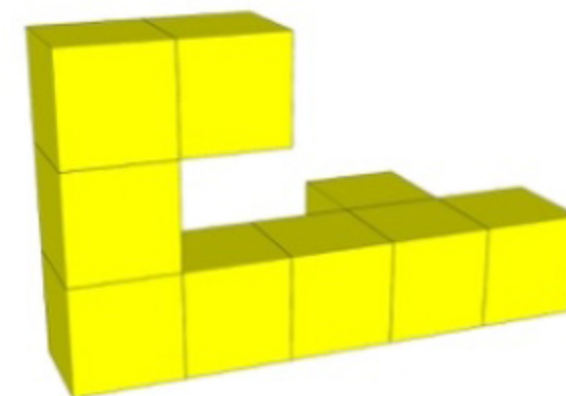

4

## 2. TRANSFORMACIJA

### 2.1. TRANSLACIJA

Translatirati prostorne elemente /kocke/ u suprotnim smjerovima, po osi 'x', za dužinu osnovnog elementa /kocke/ uz uslov da se, nakon translacije, prostorni elementi međusobno ne razdvajaju.

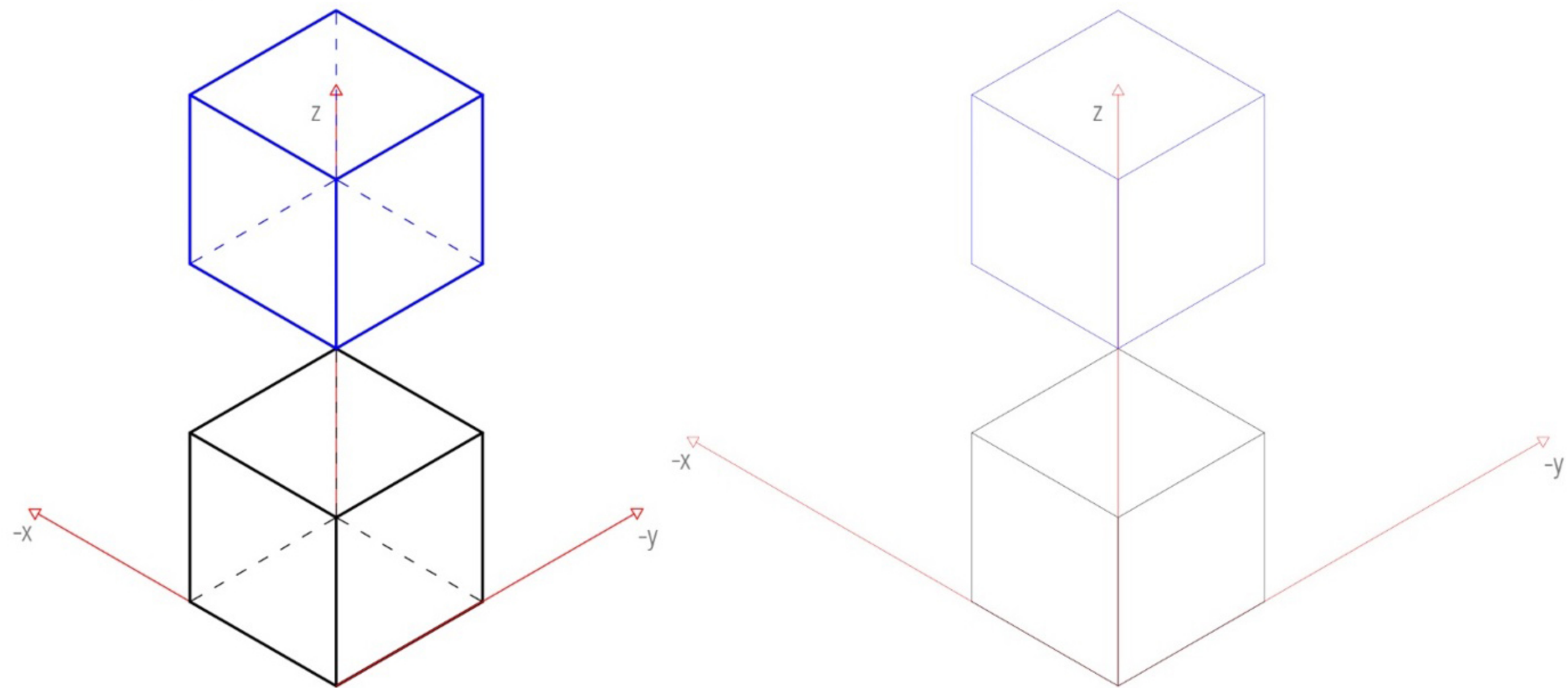

## 2. TRANSFORMACIJA

### 2.2. ROTACIJA

Rotirati prostorne elemente /kocke/, po osi 'x', za  $90^\circ$  u naznačenom smjeru (smjeru kazaljke na satu).

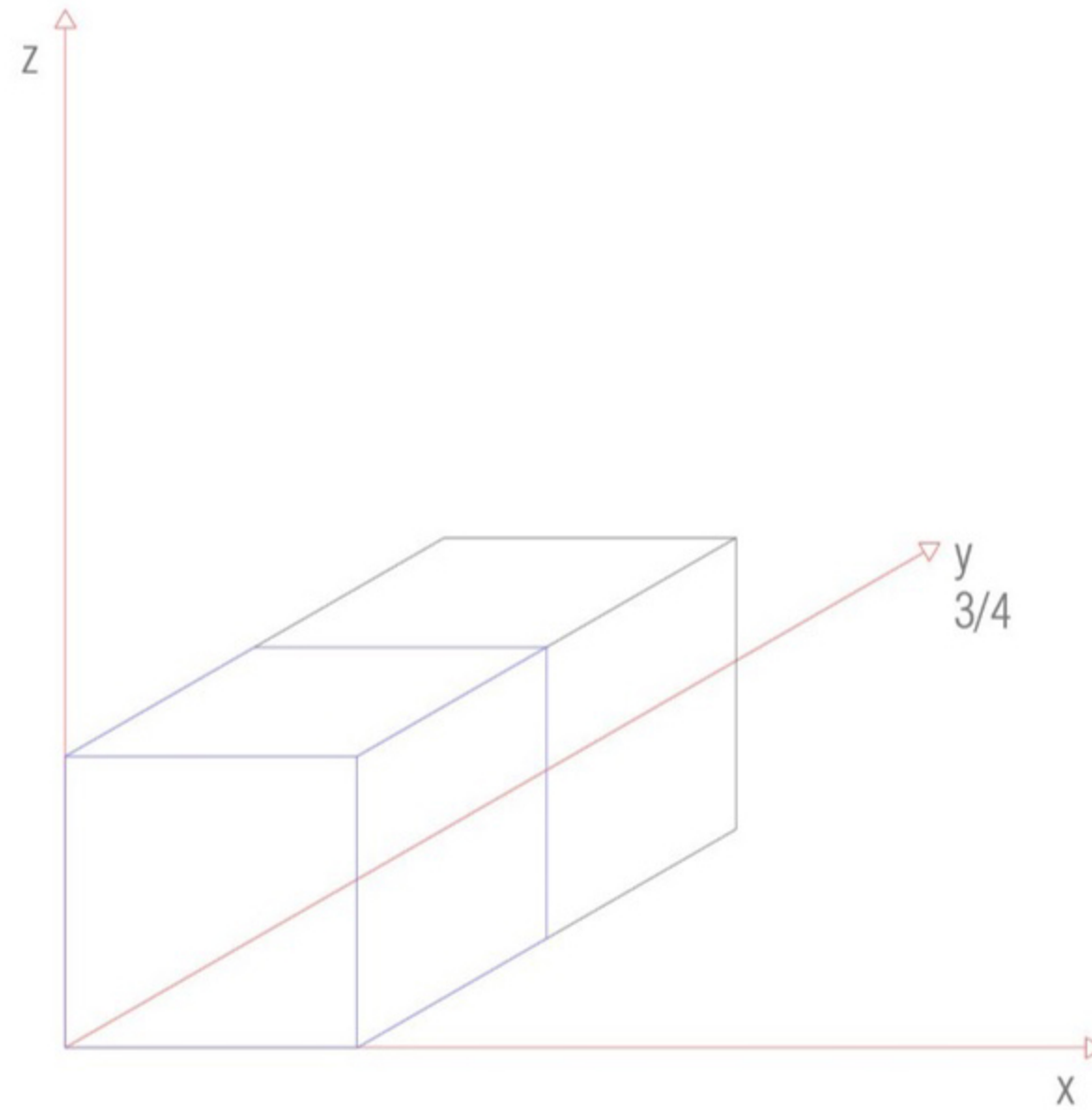
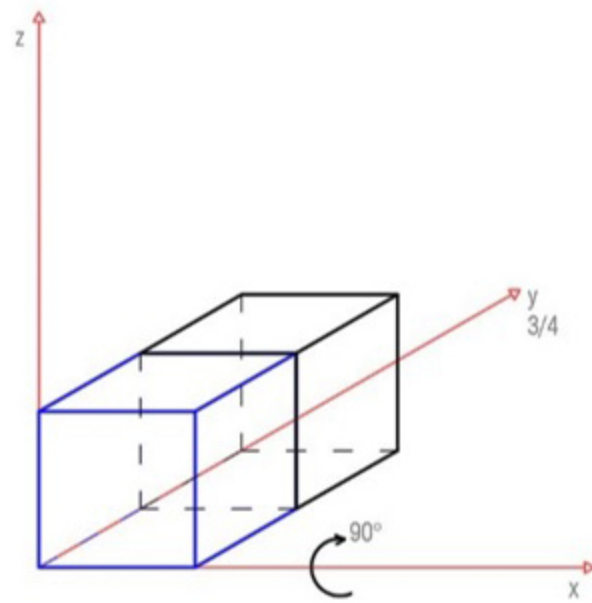



## 2. TRANSFORMACIJA

### 2.2. ROTACIJA

Rotirati prostorne elemente /kocke/, po osi 'z', za  $90^\circ$  u naznačenom smjeru (smjeru kazaljke na satu).

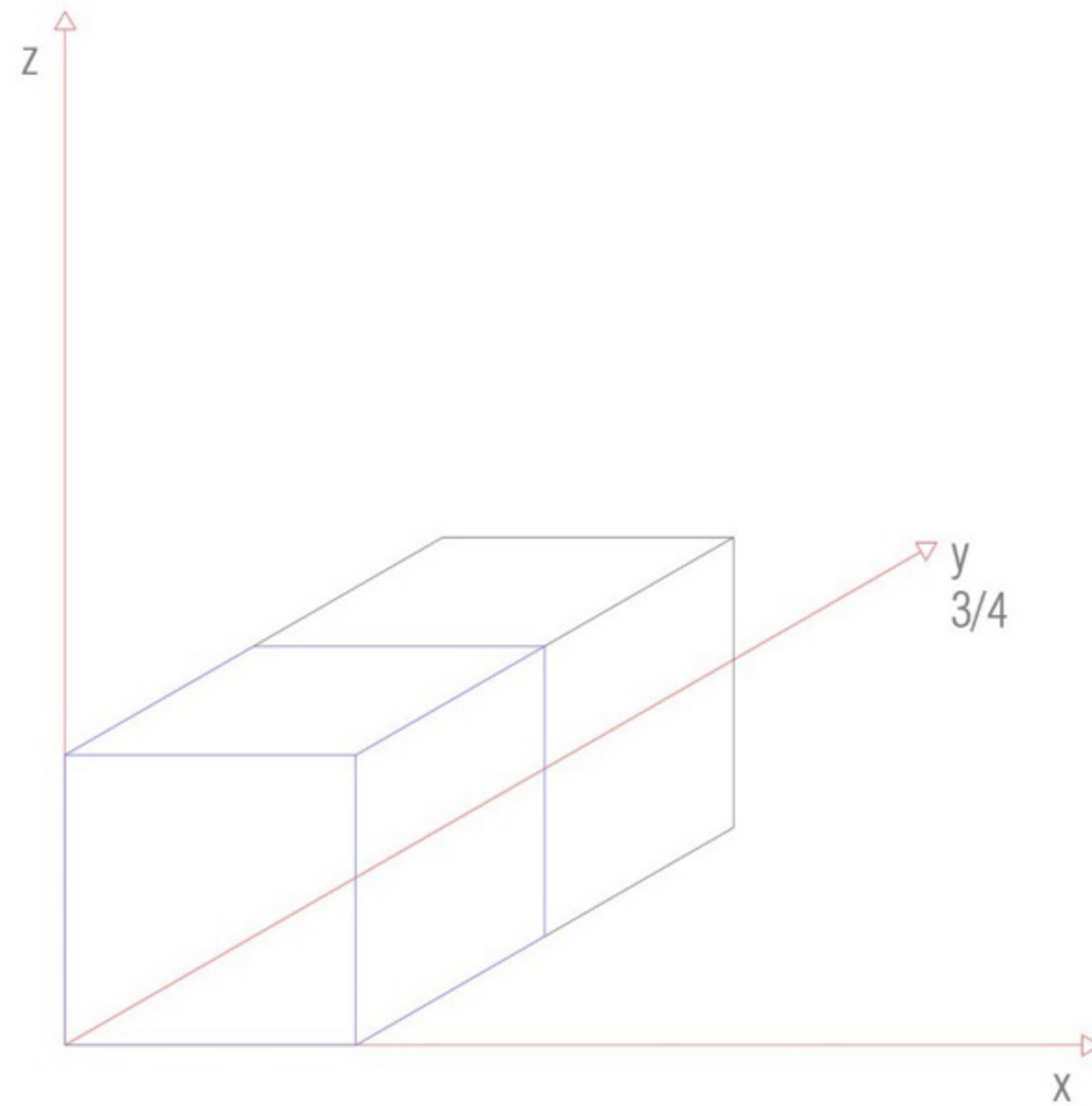
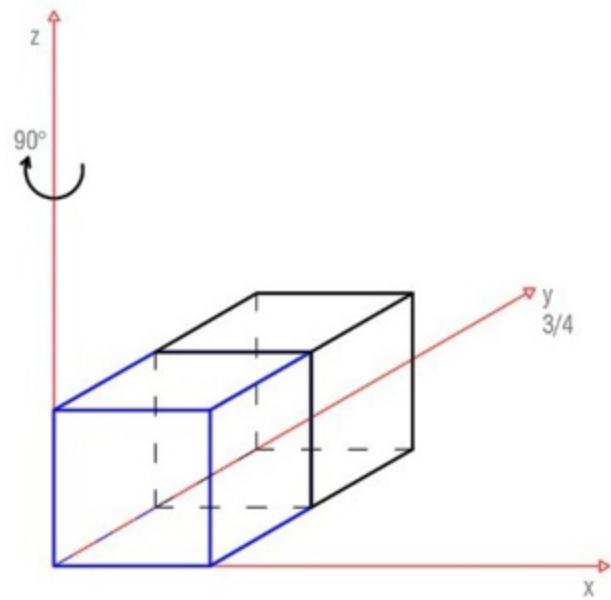

## 2. TRANSFORMACIJA

### 2.2. ROTACIJA

Rotirati prostorni sklop /tri otvorena prostorna elementa/, oko ose 'x', za  $90^\circ$  u naznačenom smjeru (smjeru suprotnom od smjera kazaljke na satu).

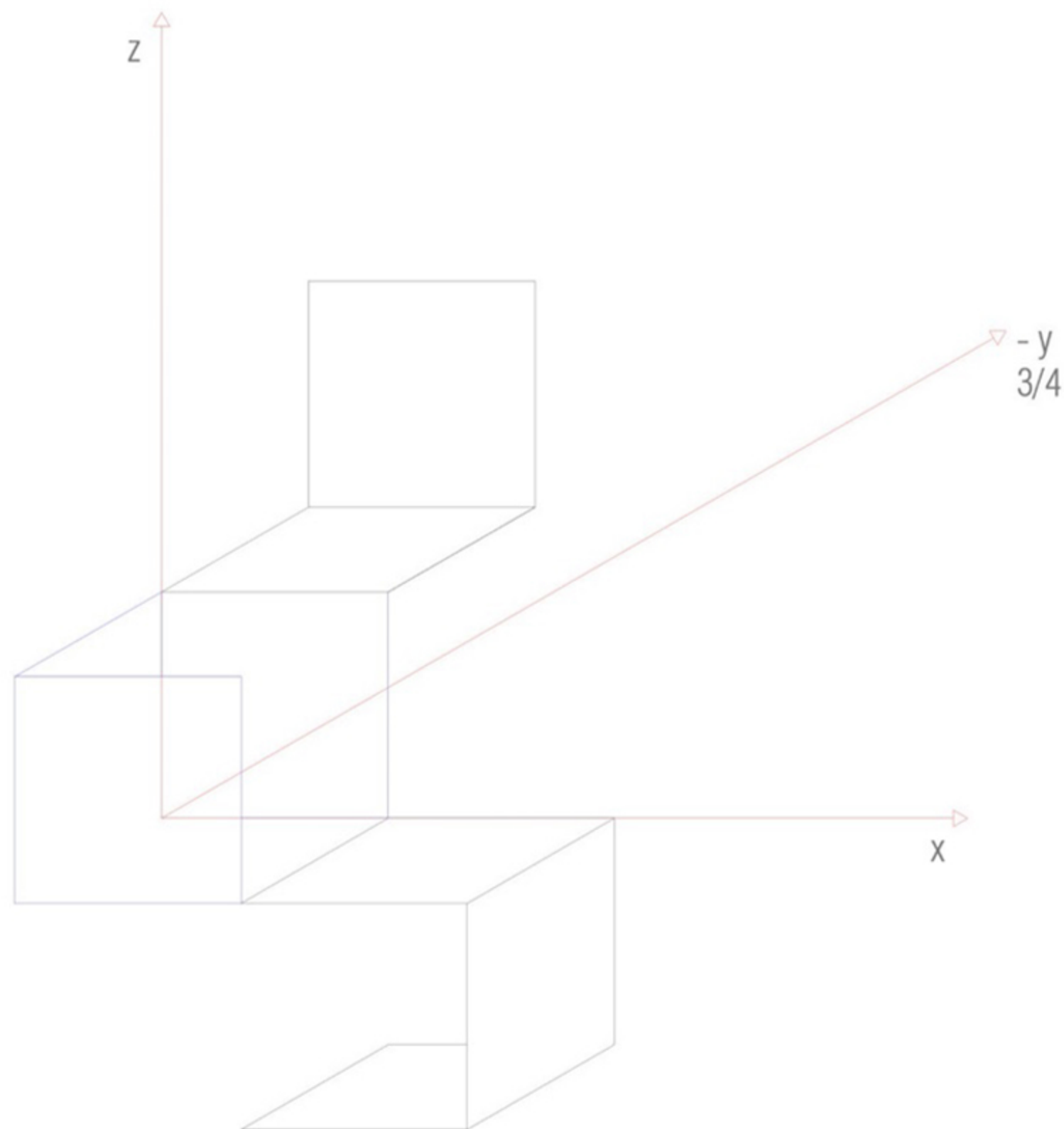
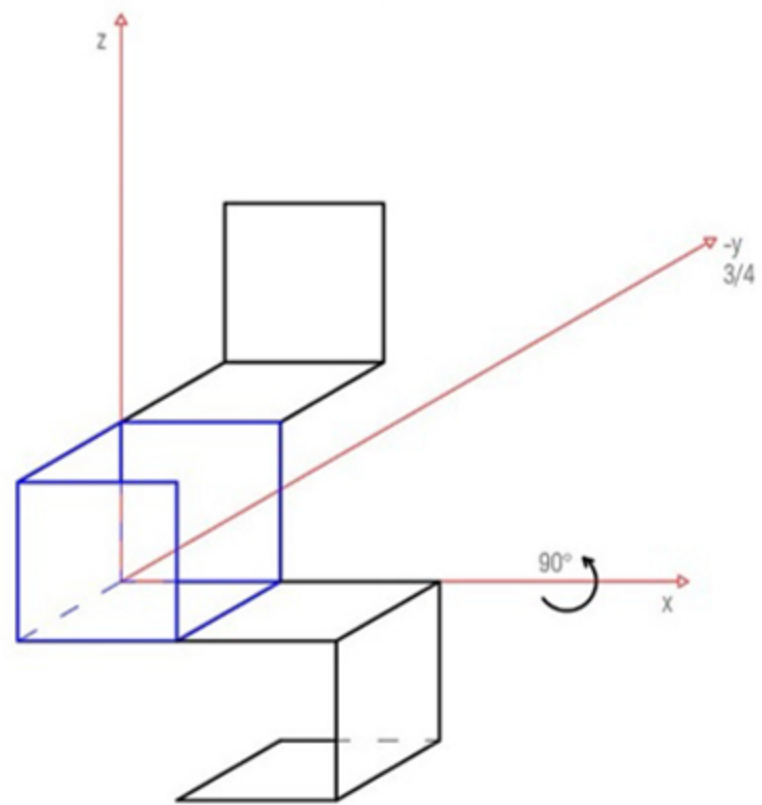



### 3. ZAPAŽANJE ELEMENATA VANJSKOG I UNUTRAŠNJEG ARHITEKTONSKOG PROSTORA

Poveži sliku dijela grada sa odgovarajućom mapom?

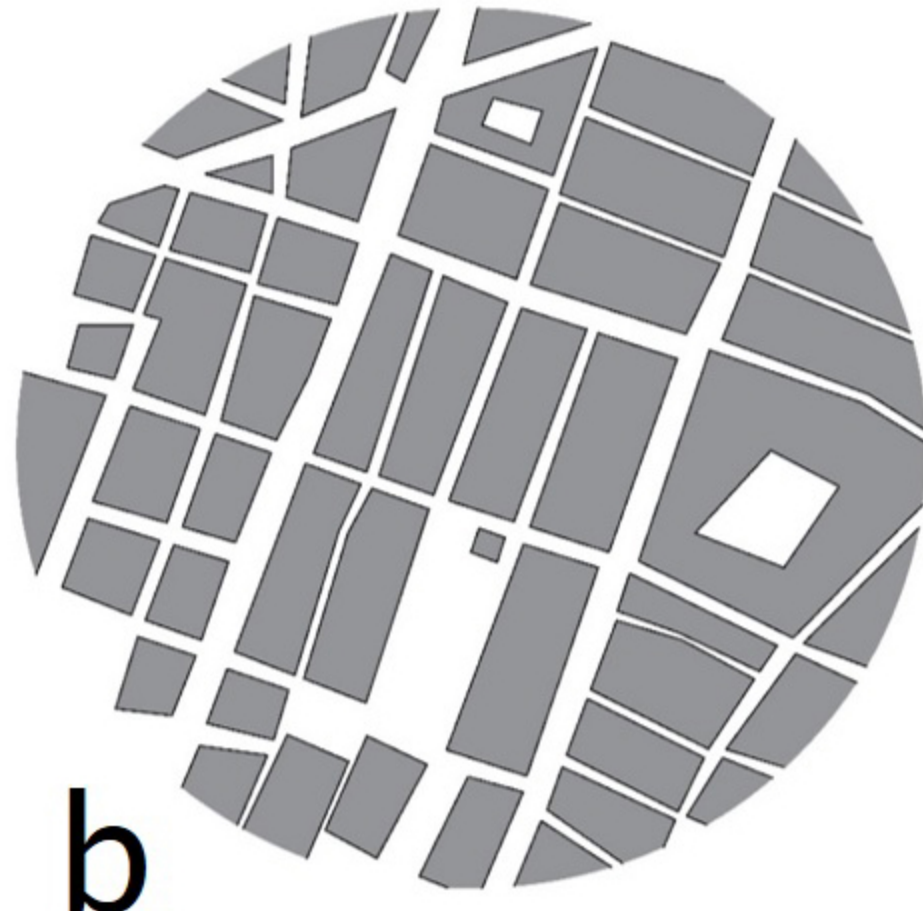
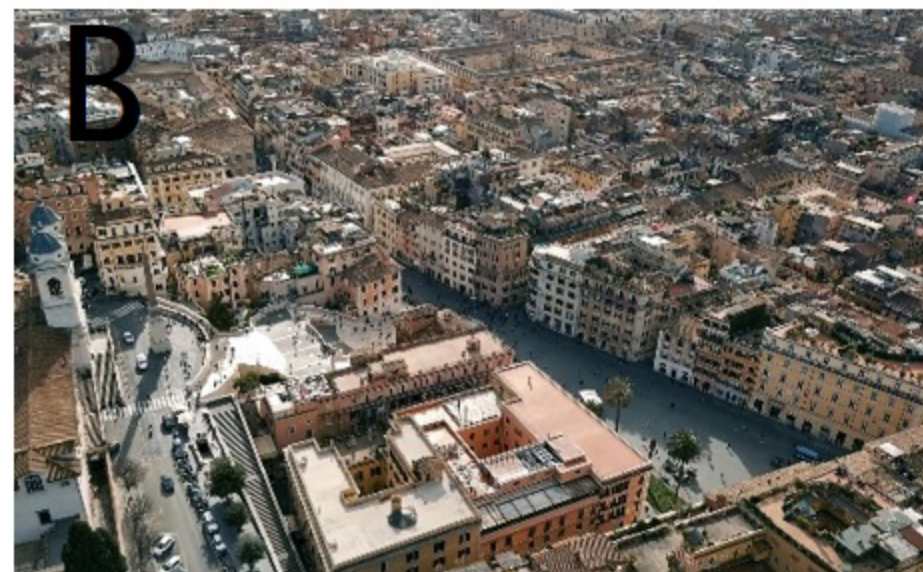
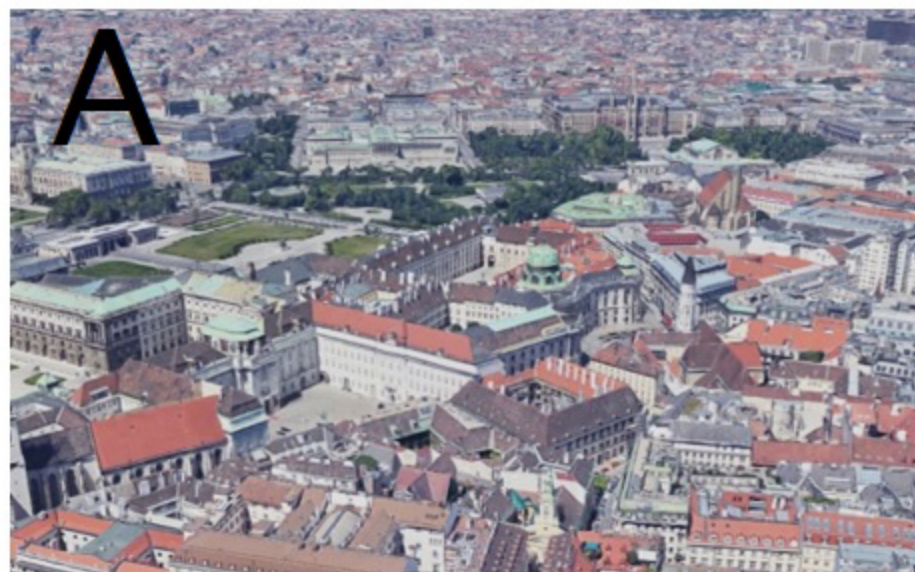



### 3. ZAPAŽANJE ELEMENATA VANJSKOG I UNUTRAŠNJEG ARHITEKTONSKOG PROSTORA

Poveži sliku unutrašnjosti objekta sa odgovarajućim tlocrtom?

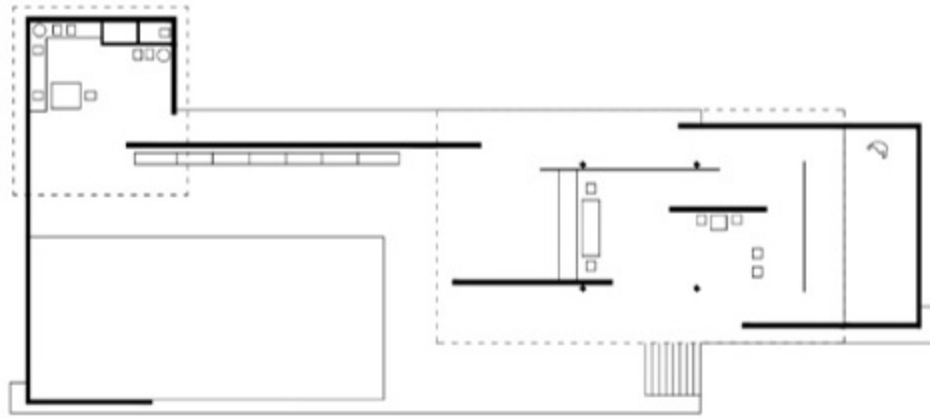
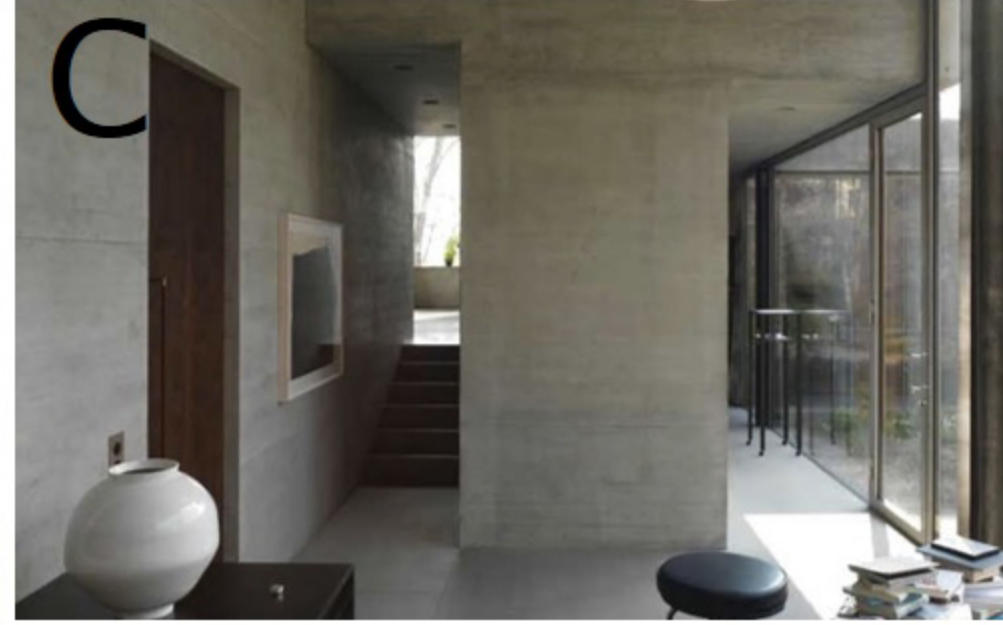

a

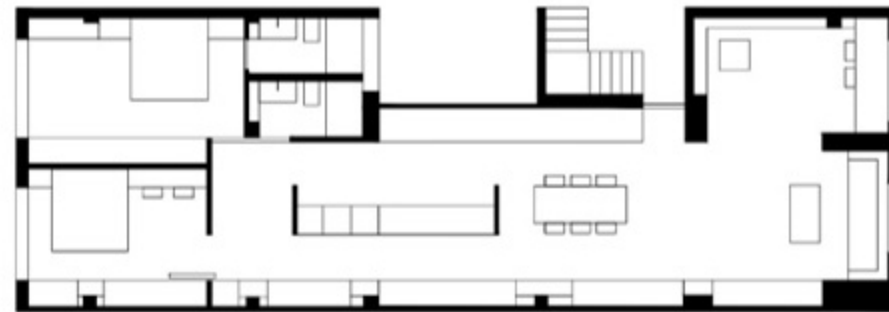

b

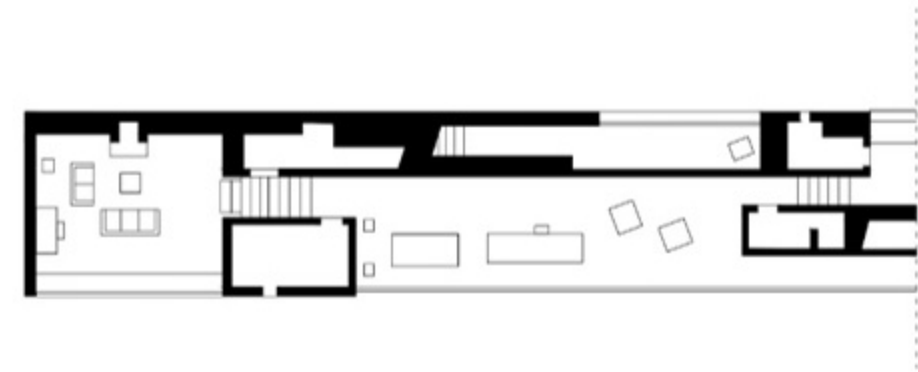

c



## 4. CRTANJE PO SJEĆANJU

CRTANJE ARHITEKTONSKOG OBJEKTA NA OSNOVU PRIKAZANE FOTOGRAFIJE.

POSMATRATI PRIKAZANI OBJEKAT /BEZ CRTANJA (TRAJANJE 3 MINUTE).  
NACRTATI OBJEKAT PO SJEĆANJU (TRAJANJE 10 MINUTA).



Notre-Dame du Haut,  
Ronchamp  
Le Corbusier, 1953.